

26

Utilizar una broca de 5/16" para hacer las perforaciones en el muro/
Use a 5/16" drill bit to drill the wall.

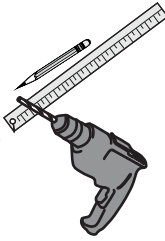

* Herramientas NO incluidas/
Tools not included

Medir y marcar las distancias, como muestra la figura/
Measure and mark the distances as shown in the figure below.

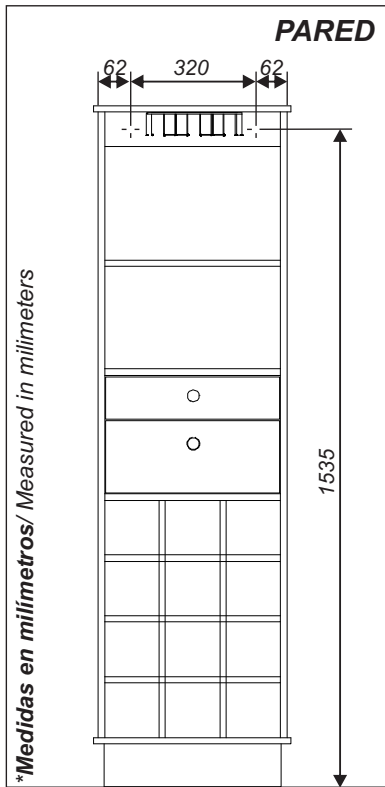

Piso terminado/ Finished Floor

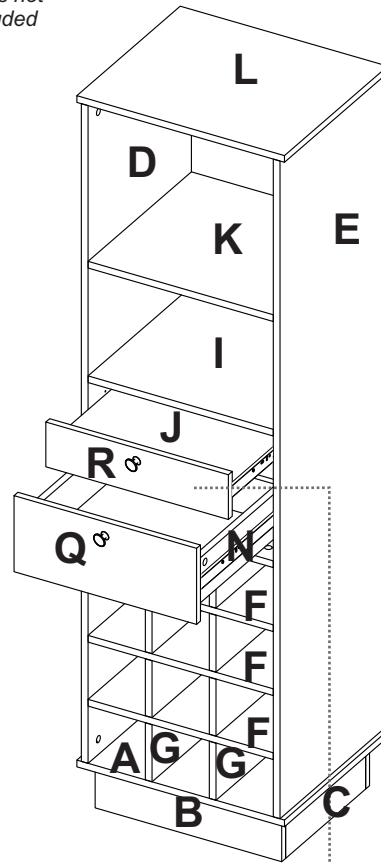

Deslice los cajones dentro del mueble / Slide the drawers inside the cabinet

Al finalizar el ajuste de los conectores, proceda a poner las tapas adhesivas/
When you finish the adjustment of the connectors, proceed to put the cover tapes



Al terminar de armar, despegue los adhesivos (en caso de que queden residuos de pegamento, limpie la superficie con alcohol) / After finish assembling, tear off the adhesives. (In case of glue residues, wipe them with alcohol)



INSTRUCCIONES DE ENSAMBLE ASSEMBLY INSTRUCTIONS

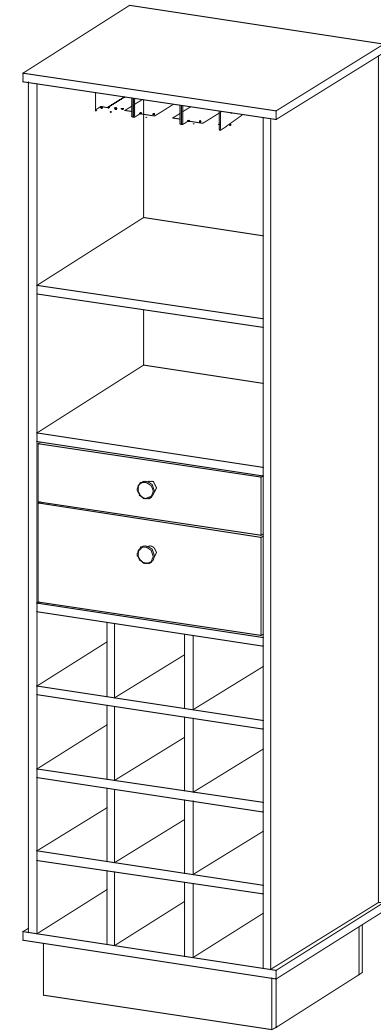

Alto/ Height: 160 cm
Ancho/ Width: 46,4 cm
Fondo/ Depth: 40 cm

LOTE No: _____

REF. BWC2363

By: **Rta design**
RTA DESIGN S.A.S.
TEL (572) 691 17 00
PBX (572) 695 91 81
CALI - COLOMBIA
www.rta.com.co

BAR CLASSIC COLOR 2
/Classic Color 2 Bar Cabinet

HERRAJES BÁSICOS PARA MUEBLES RTA

RTA FURNITURE HARDWARE (ready to assemble)

Siga las siguientes instrucciones:

1. Abrir la caja del mueble y buscar la bolsa con los herrajes.
2. Abrir el paquete de herrajes y comprobar que el contenido de las piezas es correcto.
3. Separe los herrajes para facilitar su identificación durante el armado.
4. Arme el mueble en un lugar limpio y en una superficie plana.

A continuación verá una breve explicación de cada herraje y su función principal.
Below you can see a explanation of each hardware and its main function.

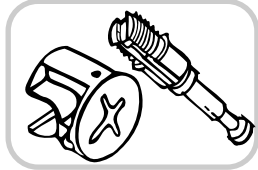

CONECTORES- PERNOS/CONNECTOR - SPREADING BOLTS

Es un herraje de unión, la cabeza esférica del perno se ubica en el centro de la caja embutida en forma de copa desde cualquier ángulo y luego se sujeta firmemente. Este permite un arme y desarme repetidamente y una unión firme que no se afloja. *It is a hardware union, spherical head of the pin is located in the center of the box embossed in the form of glass from any angle and then subject firmly. This allows for arming and disarming repeatedly and a strong union that is not loosened.*

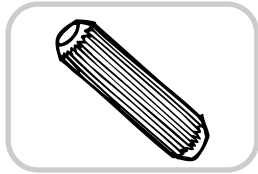

TARUGO DE MADERA/WOODEN PIN

Es un pedazo de madera corto y grueso, aprox. de 3cm a 10cm, que sirve para amarrar el mueble y darle resistencia. Tenga cuidado en aplicar una gota de pegamento en cada perforación de la cara en la que se pondrá el taquete. *It is a piece of wood short and thick, aprox. 5cm to 10cm, which serves to tie the cabinet and give it strength. Take care to apply a drop of glue drilling in each of the side you will be wooden pin.*

RECOMENDACIONES DE ARMADO

ASSEMBLY RECOMENDATIONS

El buen funcionamiento del mueble depende de su correcto armado.

Armed with a suitable furniture depends on its smooth functioning.

MINIFIX

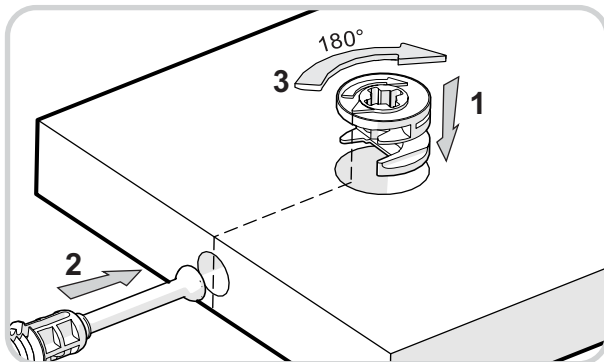

TAQUETE

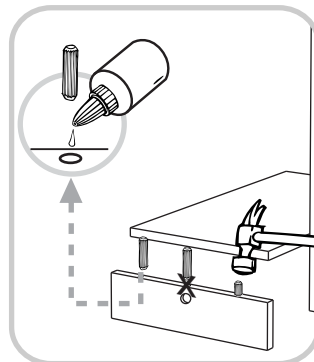

24

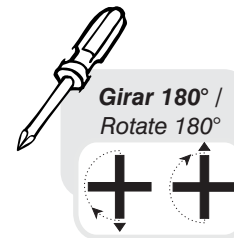
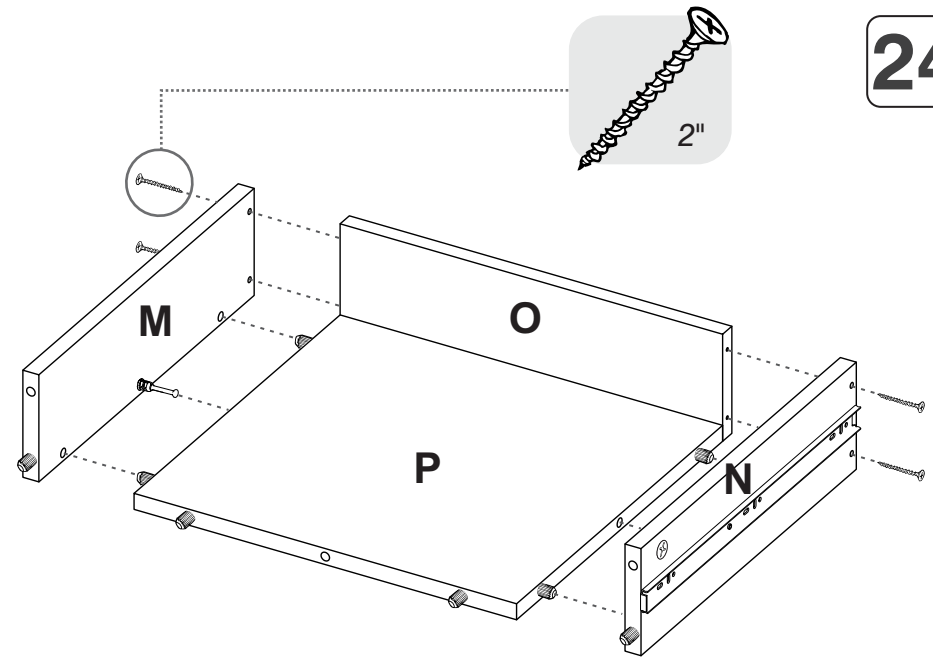

25

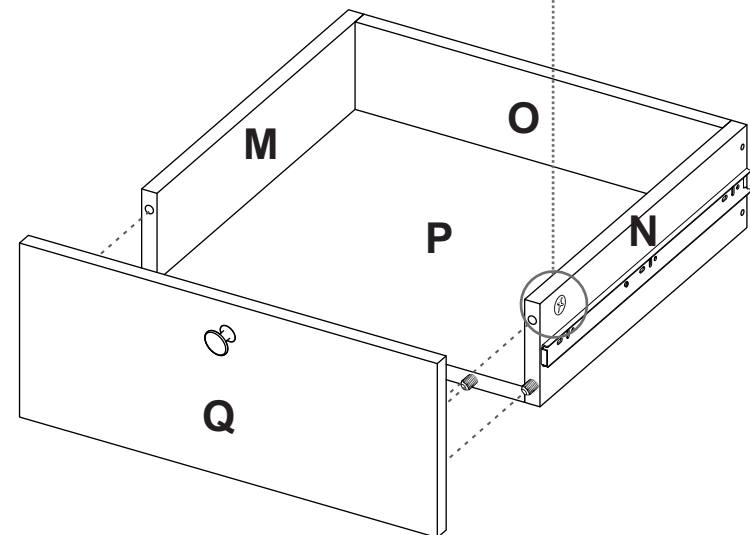

22

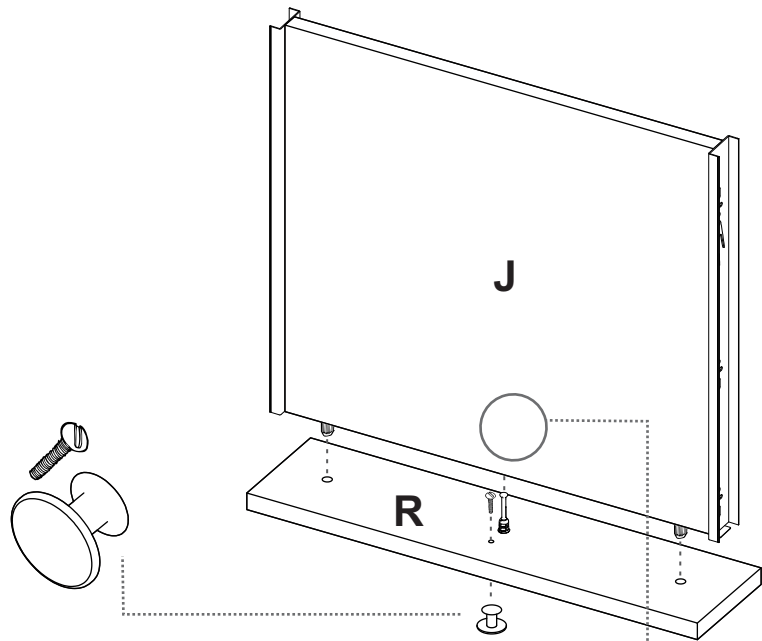

23

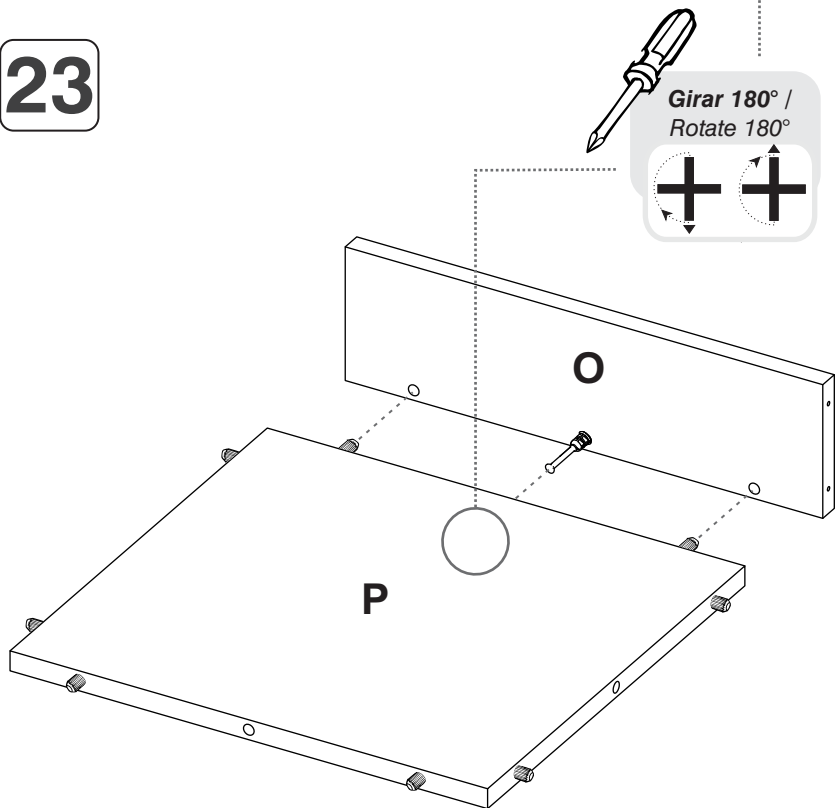

HERRAJES PARA ARMADO ASSEMBLY HARDWARE

x16



Tornillo lámina
6 X 9/16"/
Sheet Screw

x41



Minifix/
Minifix Cams

x41

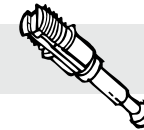

Perno minifix/
Spreading Bolt

x88



Tarugo/
Fluted Dowel Pin

x4

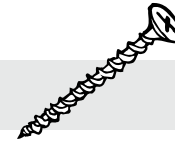

Tornillo Ensamble 2" /
Drywall Screw

x2



Chazo Mariposa +
Tornillo 2"/
Plastic Wall Anchor

x41



Tapa Adhesiva
Minifix/
Cover Caps

x2

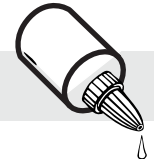

Pegante/
Glue

x2



Tornillo Manija 3/4"/
Handle Screw

x2



Botón Zamak/
Knob

x8



Deslizador Puntilla/
Nail-on Glide

x8



Puntilla/
Nail



IMPORTANTE

TENER PRECAUCIÓN AL ABRIR LA BOLSA DE HERRAJES PARA NO EXTRAVIAR NINGUNO. COMPRUEBE QUE EL CONTENIDO DE LAS PIEZAS SEA EL CORRECTO. EN CASO QUE FALTE ALGUNA PIEZA O ESTE DEFECTUOSA DEVUELVA LAS PIEZAS AL ALMACÉN CON SU FACTURA PARA EFECTUAR EL CAMBIO DE LAS PIEZAS Y/O LOS HERRAJES LO MÁS PRONTO POSIBLE. / PLEASE BE CAUTIOUS WHEN OPENING THE HARDWARE BAG TO NOT LOSE ANY. CHECK THE CONTENTS OF THE PARTS ARE CORRECT. IF ANY PART IS MISSING OR DEFECTIVE PLEASE RETURN THE PARTS TO THE STORE WITH THE PRODUCT INVOICE ATTACHED TO MAKE EFFECTIVE THE REPLACEMENT OF THE DEFECTIVE PIECES OR WARDWARE AS SOON AS POSSIBLE.

HERRAJES PARA ARMADO ASSEMBLY HARDWARE

x3



Tornillo Ensamble 1/2"/
Drywall Screw

x1

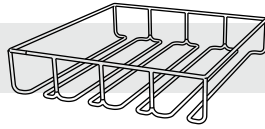

Colgador de Copas/
Wine Glass Rack

x2

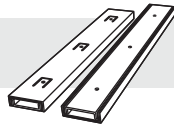

Riel Extensión Total/
Full Extension Drawer
Slide



IMPORTANTE

TENER PRECAUCIÓN AL ABRIR LA BOLSA DE HERRAJES PARA NO EXTRAVIAR NINGUNO. COMPRUEBE QUE EL CONTENIDO DE LAS PIEZAS SEA EL CORRECTO. EN CASO QUE FALTE ALGUNA PIEZA O ESTE DEFECTUOSA DEVUELVA LAS PIEZAS AL ALMACÉN CON SU FACTURA PARA EFECTUAR EL CAMBIO DE LAS PIEZAS Y/O LOS HERRAJES LO MÁS PRONTO POSIBLE. / PLEASE BE CAUTIOUS WHEN OPENING THE HARDWARE BAG TO NOT LOSE ANY. CHECK THE CONTENTS OF THE PARTS ARE CORRECT. IF ANY PART IS MISSING OR DEFECTIVE PLEASE RETURN THE PARTS TO THE STORE WITH THE PRODUCT INVOICE ATTACHED TO MAKE EFFECTIVE THE REPLACEMENT OF THE DEFECTIVE PIECES OR WARDWARE AS SOON AS POSSIBLE.



Girar 180° /
Rotate 180°

1

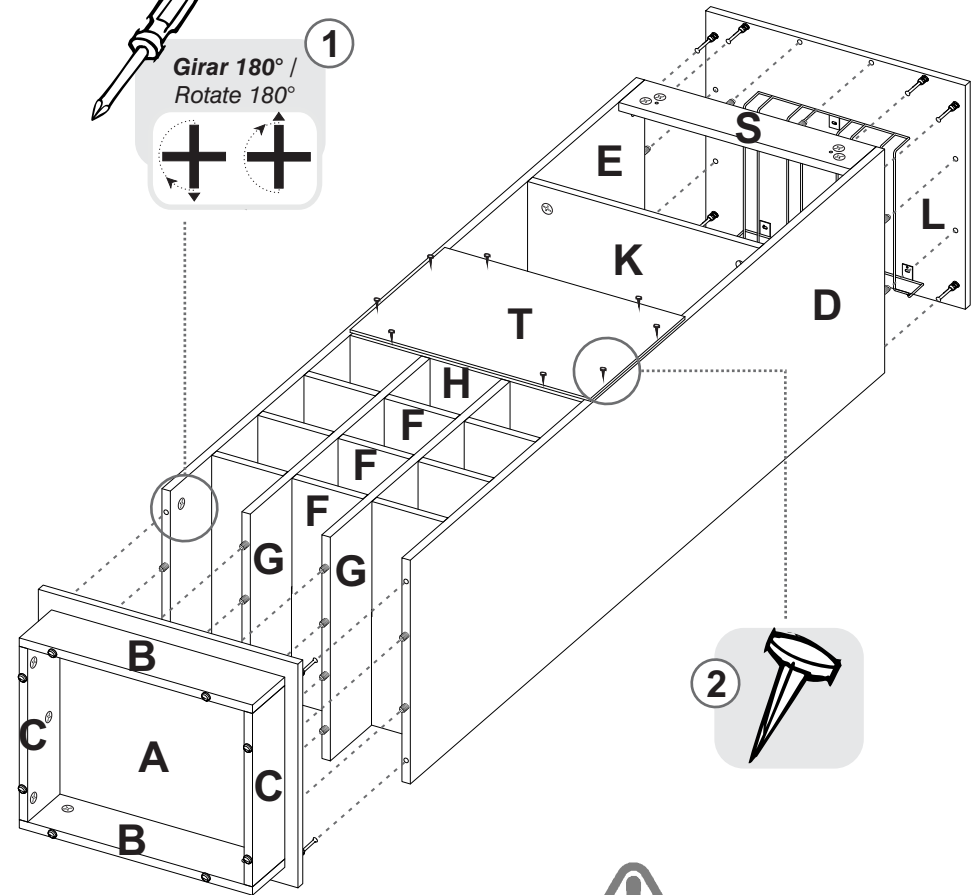
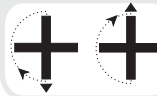

2



IMPORTANTE

**Voltear el mueble cuidadosamente
para ensamblar el fondo/
Be careful turning over the cabinet**

19

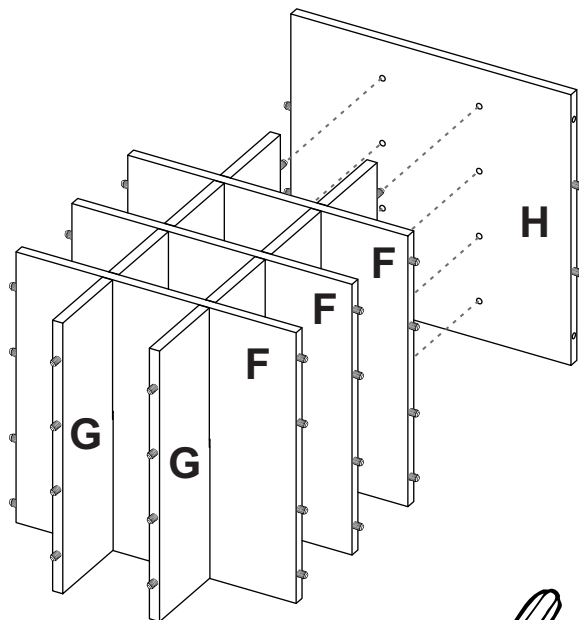

20

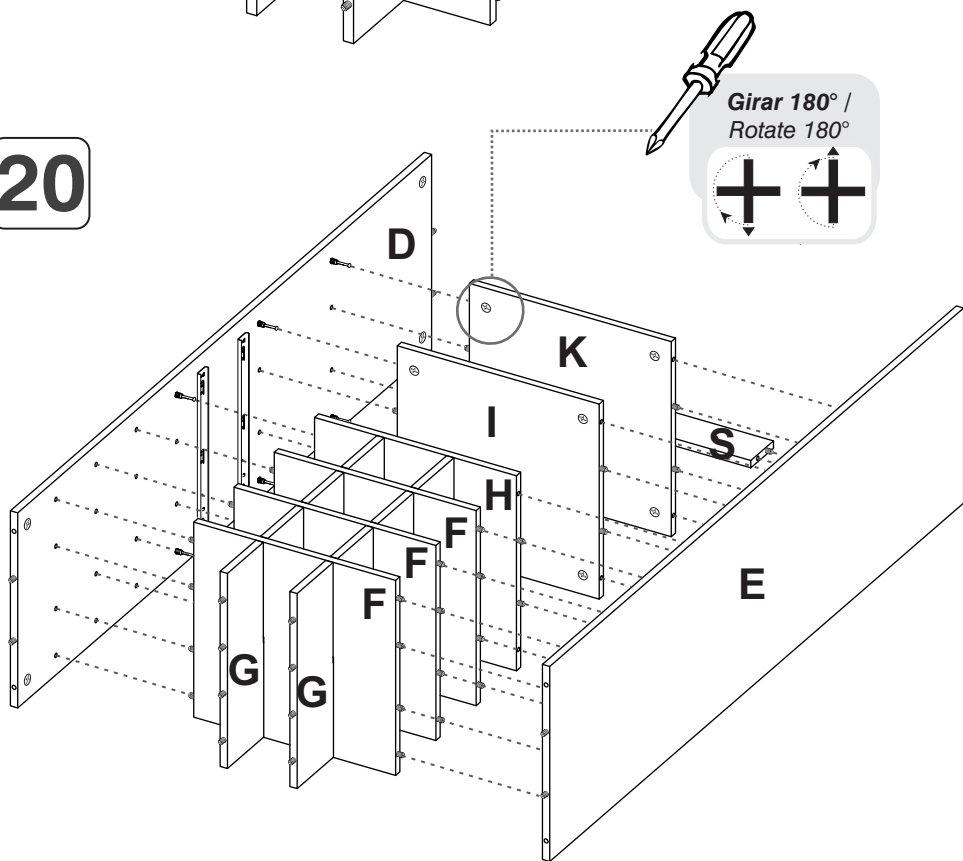

Girar 180° /
Rotate 180°

PIEZAS DE ARMADO
ASSEMBLY PARTS

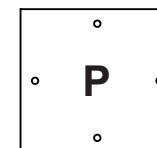
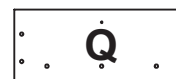
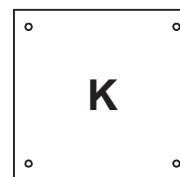
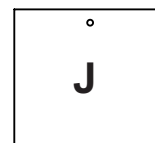
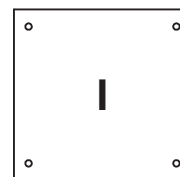
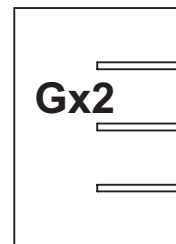
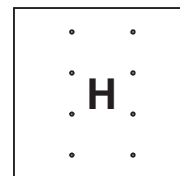
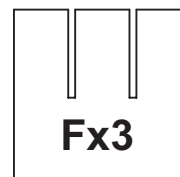
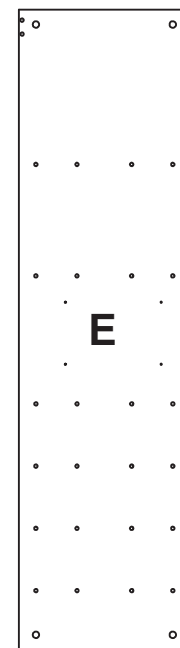
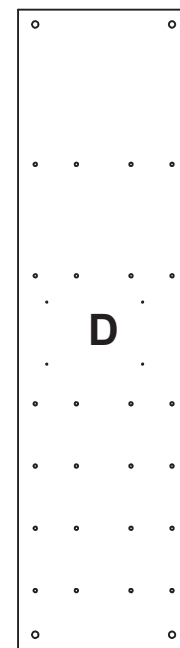
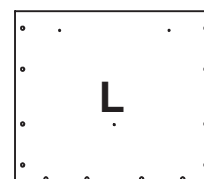
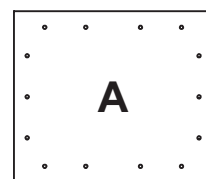

IMPORTANTE

ANTES DE EMPEZAR A ARMAR EL MUEBLE LEA DETENIDAMENTE LAS INSTRUCCIONES. SE RECOMIENDA ARMAR EL MUEBLE SOBRE LA CAJA O SOBRE UNA SUPERFICIE LISA Y CUBIERTA, PARA NO RAYARLO / BEFORE STARTING TO ASSEMBLE THE FURNITURE, CAREFULLY READ THE INSTRUCTIONS. IT IS RECOMMENDED TO ASSEMBLE THE FURNITURE ON THE BOX OR ON A FLAT AND COVERED SURFACE IN ORDER TO NOT SCRATCH THE PRODUCT.

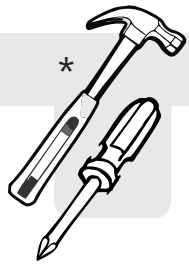

*

*(Herramientas NO incluidas) *Tools NOT Included

17

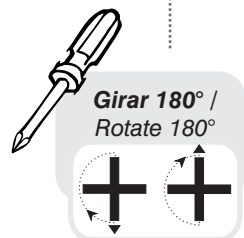
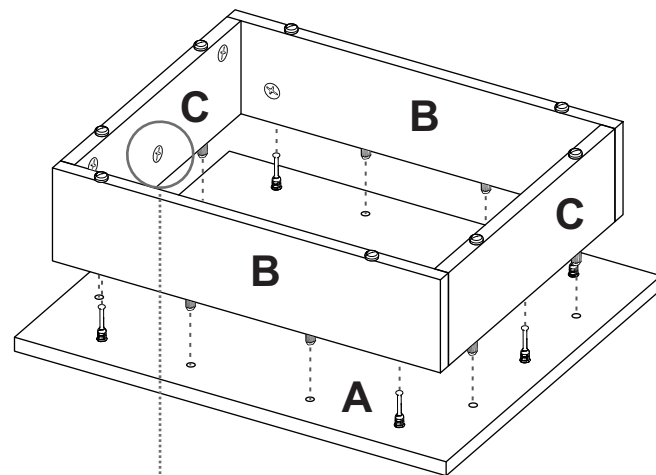
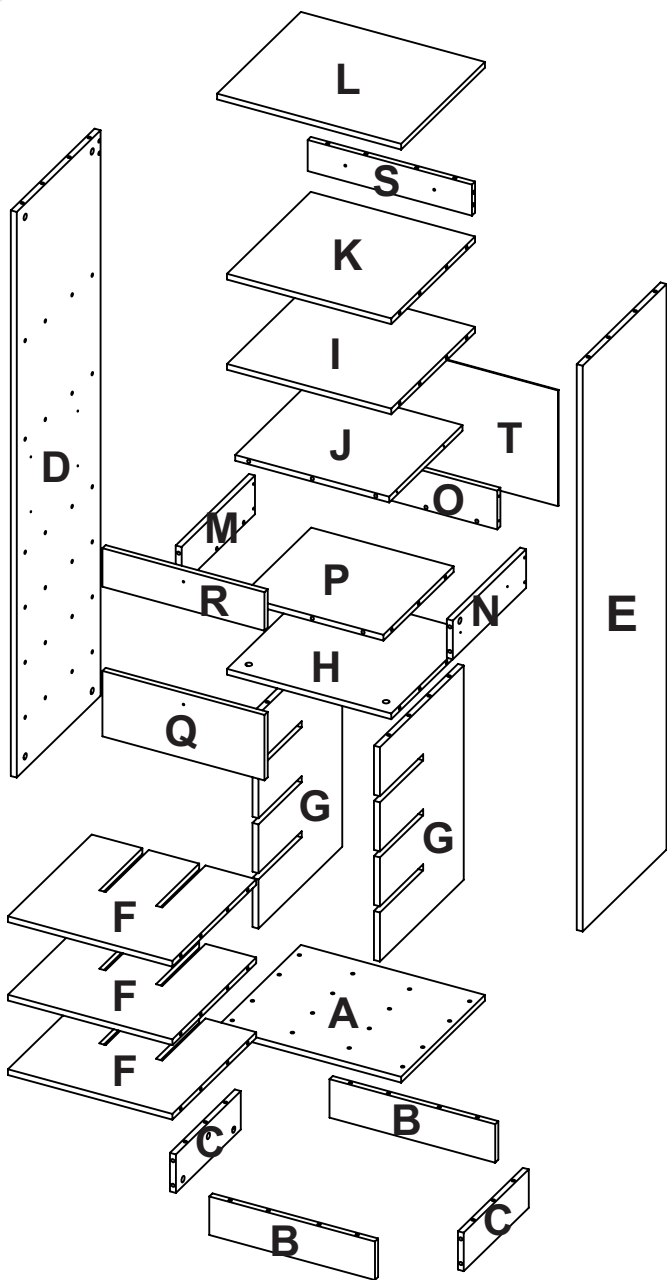

18

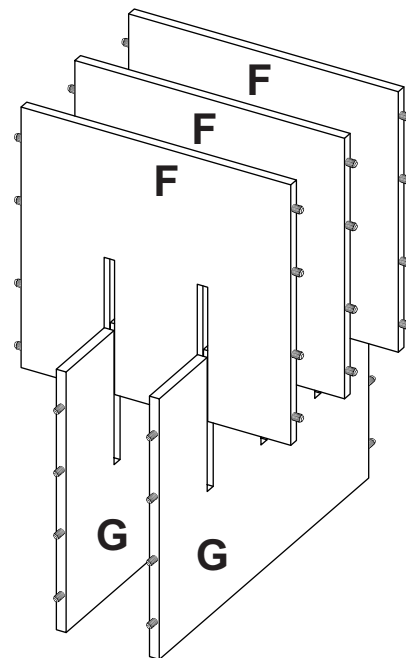

15

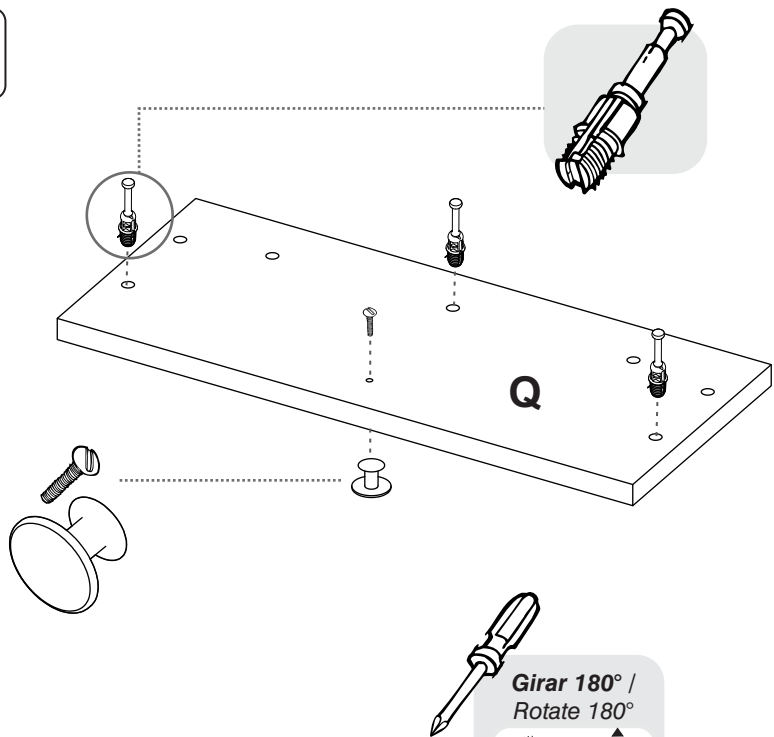

16

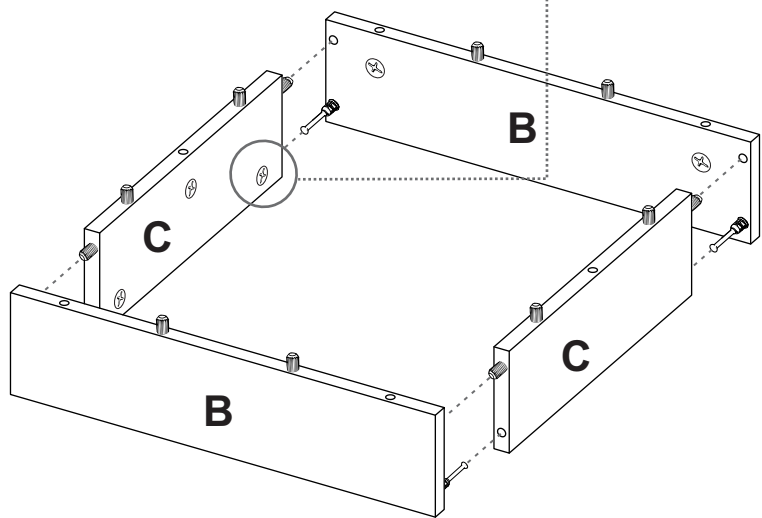

SE RECOMIENDA ARMAR EL MUEBLE ENTRE DOS PERSONAS / IT IS RECOMMENDED TO ASSEMBLE THE PRODUCT BETWEEN TWO PEOPLE

1

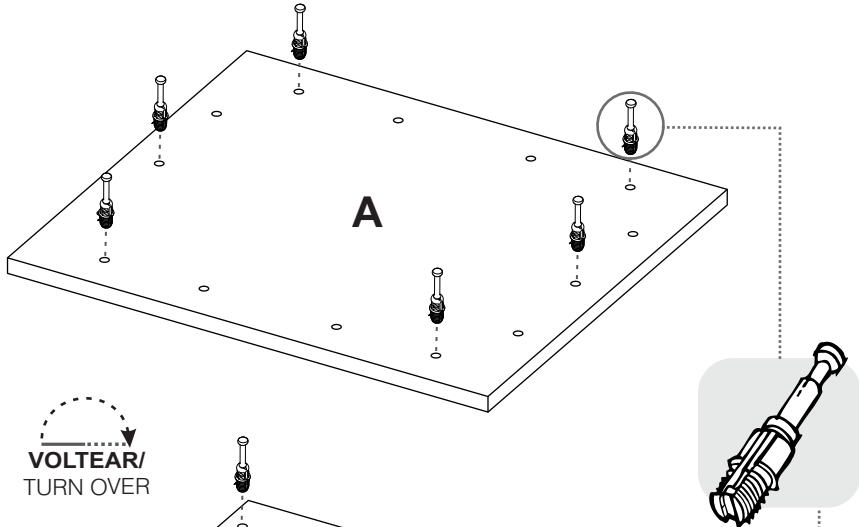

2

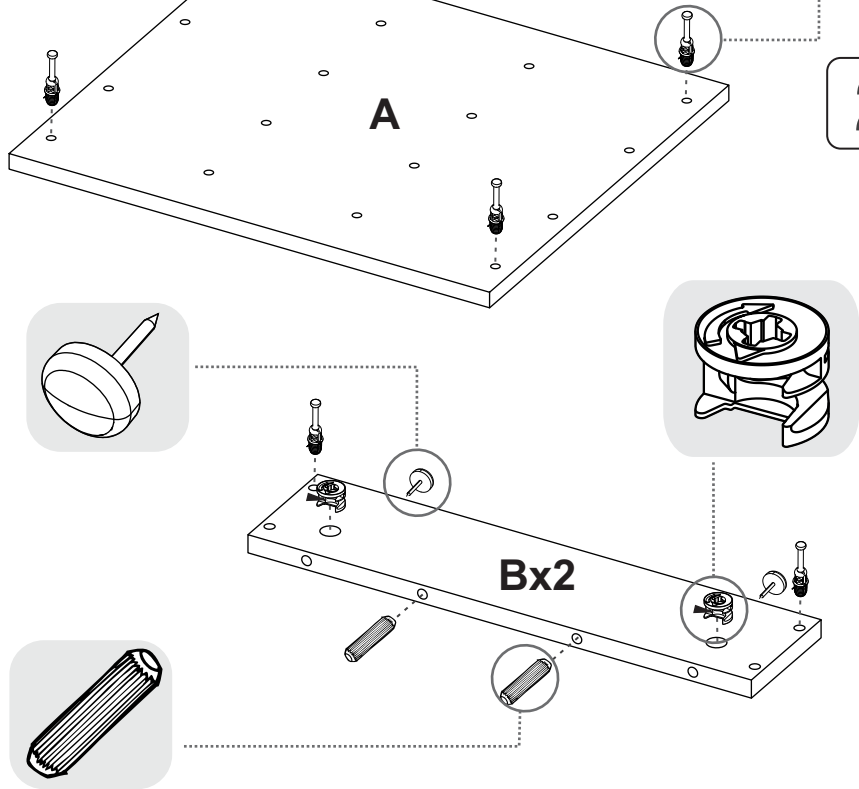

3

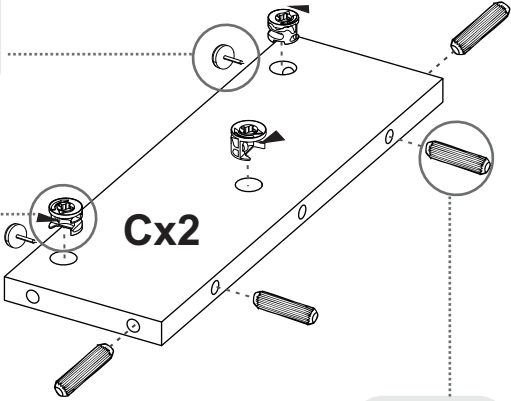

Cx2



4

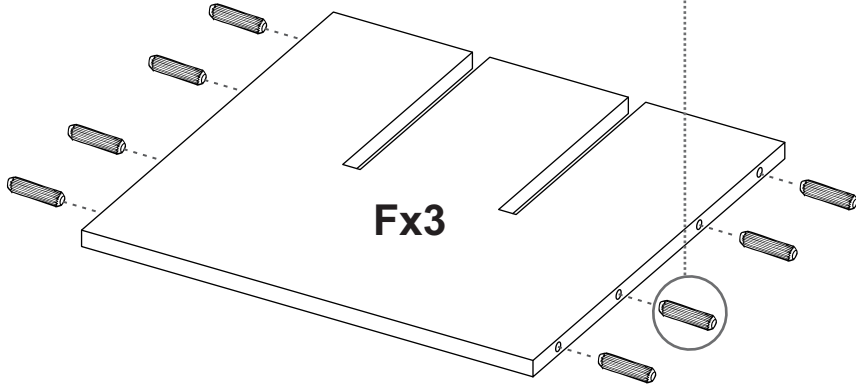

Fx3

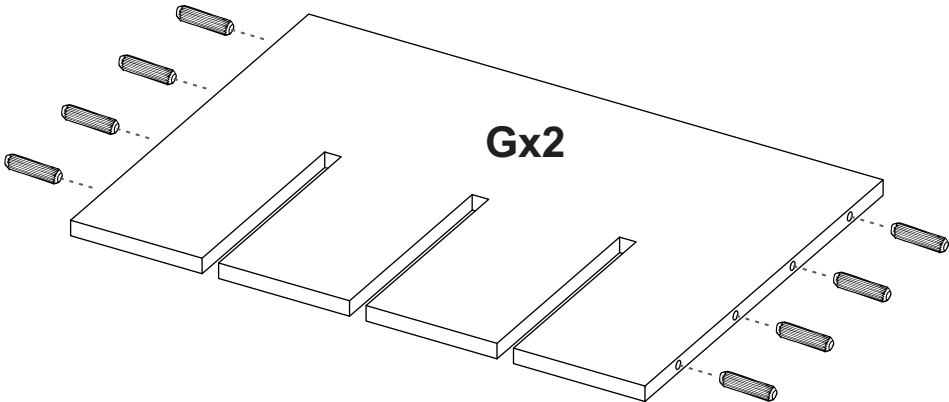

Gx2

13

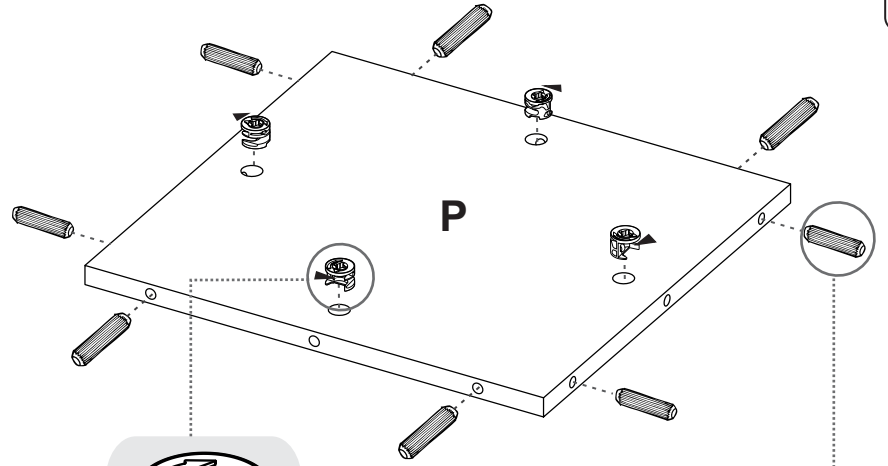

P

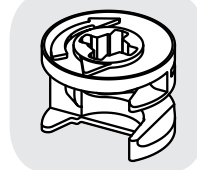

14

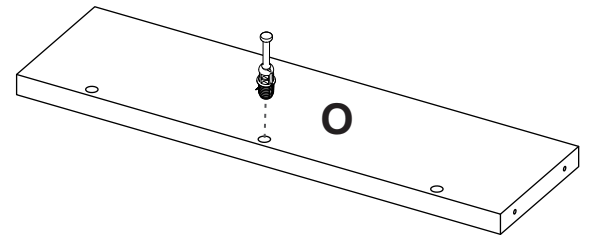

O

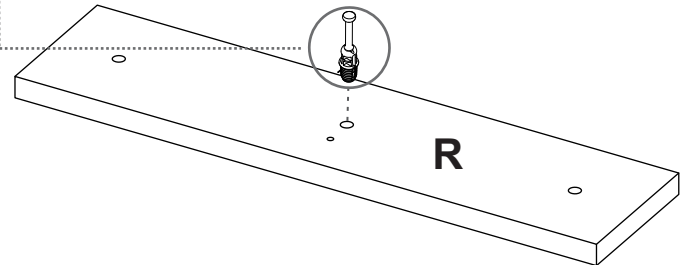

R

11

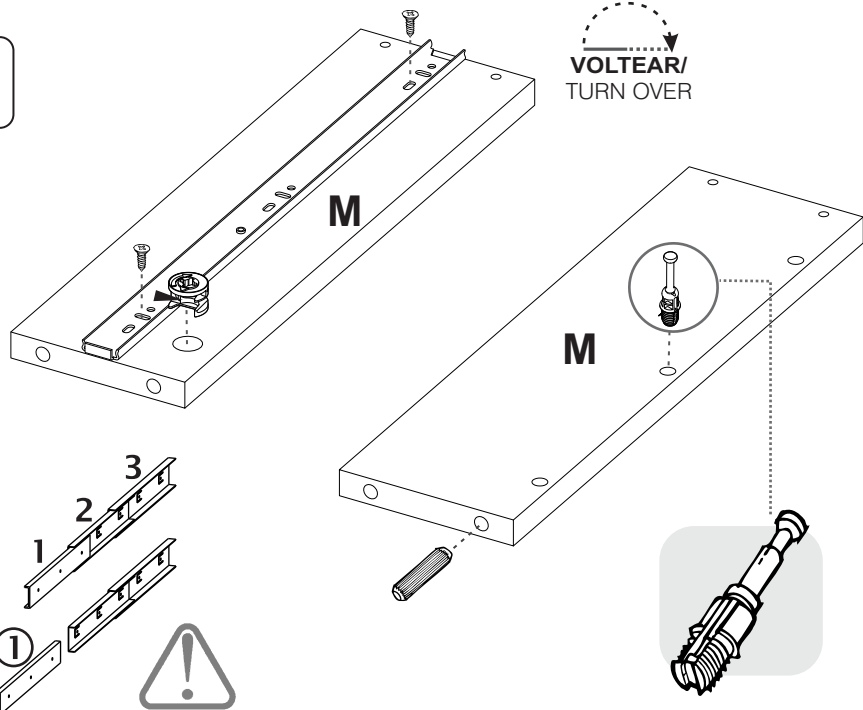

VOLTEAR/
TURN OVER

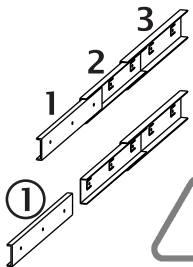

**PARA PONER RIEL EN LATERAL DEL CAJÓN/
When placing the slide on the side of the drawer:**
Revisar que el **tope metálico** del riel quede en la **PARTE DELANTERA**/
The **metallic stop** should be placed on the front.

12

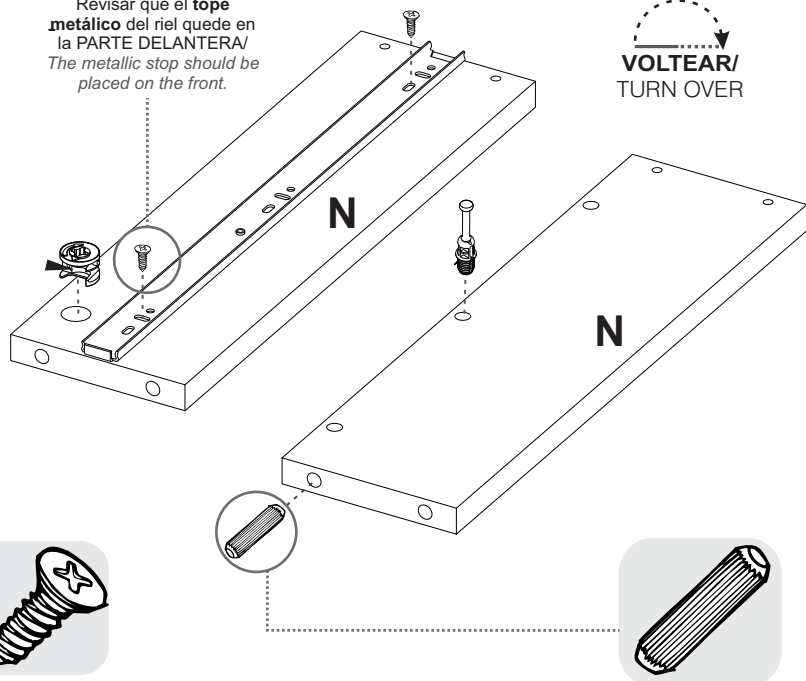

VOLTEAR/
TURN OVER



5

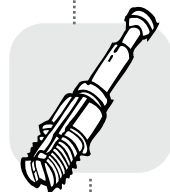
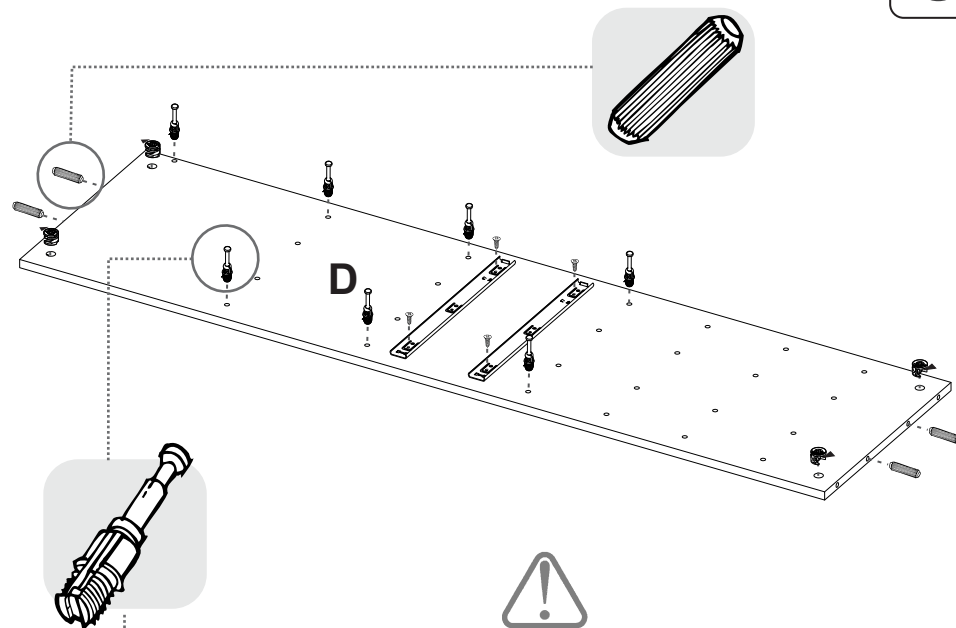

**PARA PONER RIEL EN LATERAL DEL MUEBLE/
When placing the slide on the side of the cabinet:**
Revisar que el **tope plástico** del riel quede en la **PARTE TRASERA**/
The **plastic stop** should be placed on the rear.

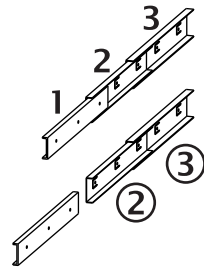

6

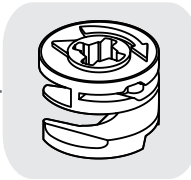
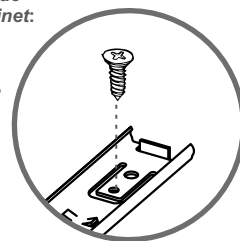
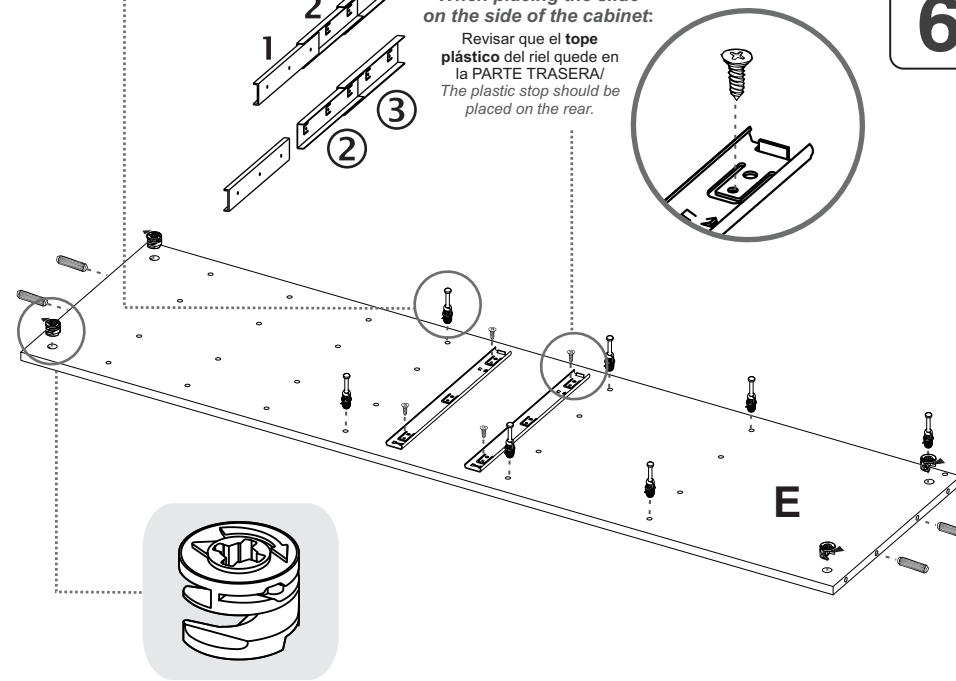

7

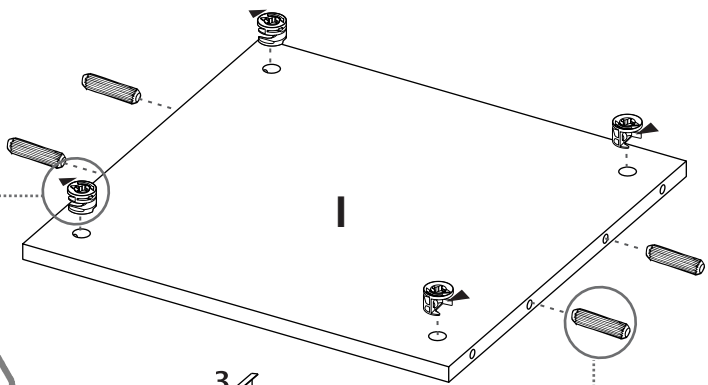
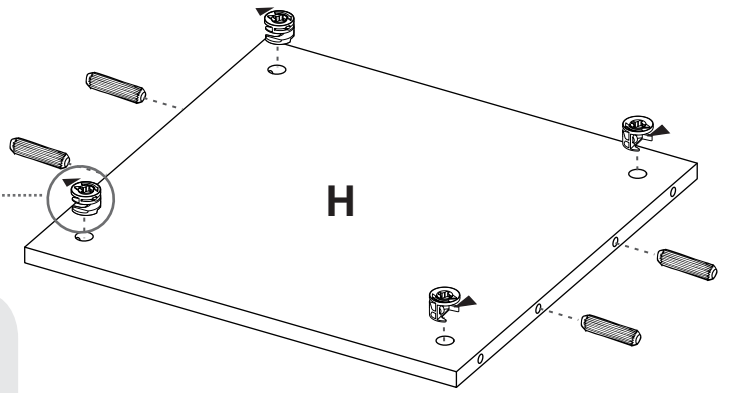

8



**PARA PONER RIEL EN LATERAL DEL CAJÓN/
When placing the slide on the side of the drawer:**
Revisar que el **tope metálico** del riel quede en la **PARTE DELANTERA**!
The metallic stop should be placed on the front.

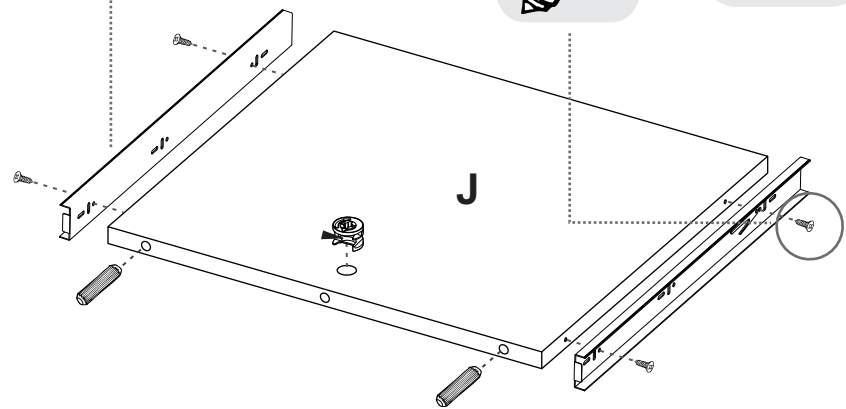
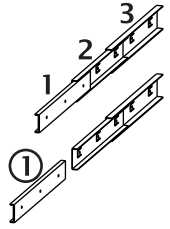

9

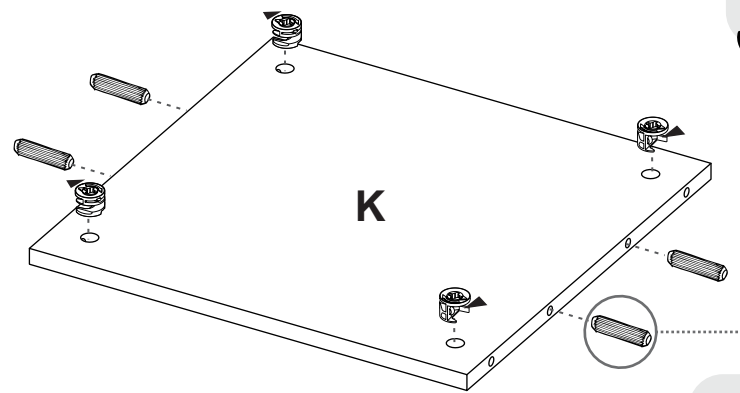
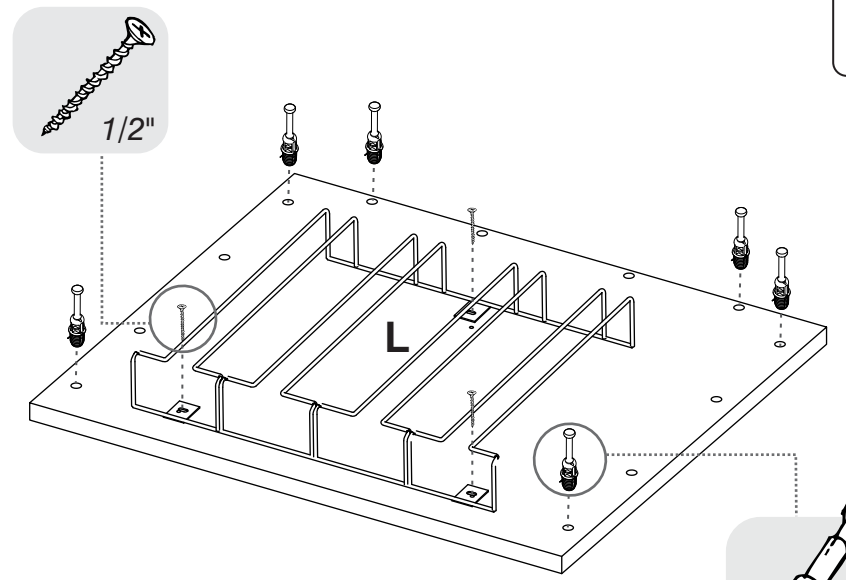

10

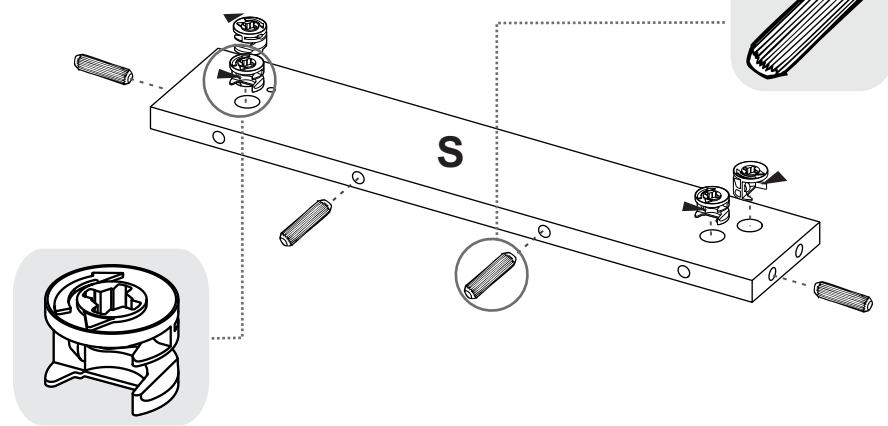

BIBLIOTECA CLASSIC COLOR VEDRA



TUHOME[®]
CONCEPT | DESIGN

INSTRUCCIONES DE ARMADO BIBLIOTECA CLASSIC COLOR VEDRA

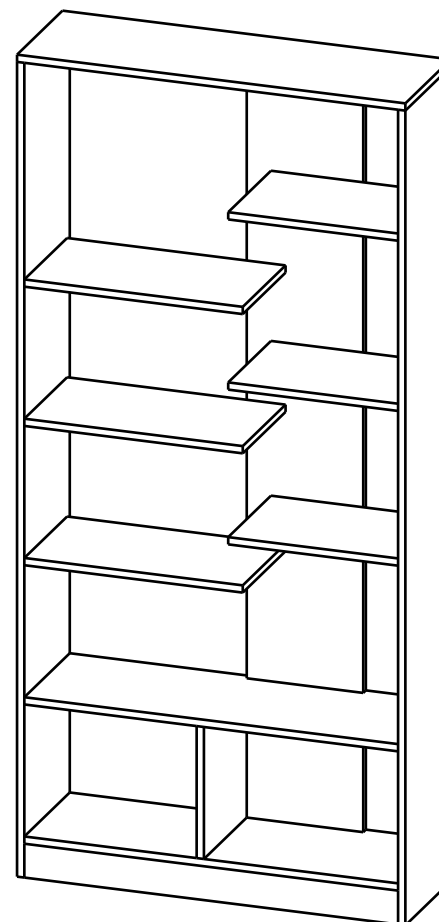

TUHOME[®]
CONCEPT | DESIGN

HECHO EN COLOMBIA

BY

Rtd
design

GARANTÍA: 3 MESES - DESDE LA FECHA DE SU COMPRA -

ALTO 170 CM / ANCHO 80 CM / FONDO 26 CM

REF. BCW1861

HECHO EN COLOMBIA

HERRAJES BÁSICOS PARA MUEBLES RTA

Siga las siguientes instrucciones:

1. Abrir la caja del mueble y buscar la bolsa con los herrajes.
2. Abrir el paquete de herrajes y comprobar que el contenido de las piezas es correcto.
3. Separe los herrajes para facilitar su identificación durante el armado.
4. Arme el mueble en un lugar limpio y en una superficie plana.

A continuación verá una breve explicación de cada herraje y su función principal.

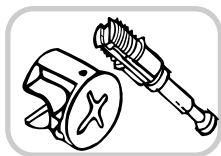

MINIFIX - PERNOS/MINIFIX CONNECTOR - DOWELS
 Es un herraje de unión, la cabeza esférica del perno se ubica en el centro de la caja embutida en forma de copa desde cualquier ángulo y luego se sujeta firmemente. Este permite un arme y desarme repetidamente y una unión firme que no se afloja.

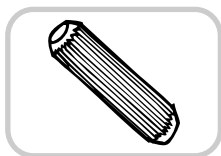

TARUGO/WOOD DOWEL PIN
 Es un pedazo de madera corto y grueso, aprox. de 5cm a 10cm, que sirve para amarrar el mueble y darle resistencia. Tenga cuidado en aplicar una gota de pegamento en cada perforación de la cara en la que se pondrá el tarugo.

RECOMENDACIONES DE ARMADO

El buen funcionamiento del mueble depende de su correcto armado.

MINIFIX

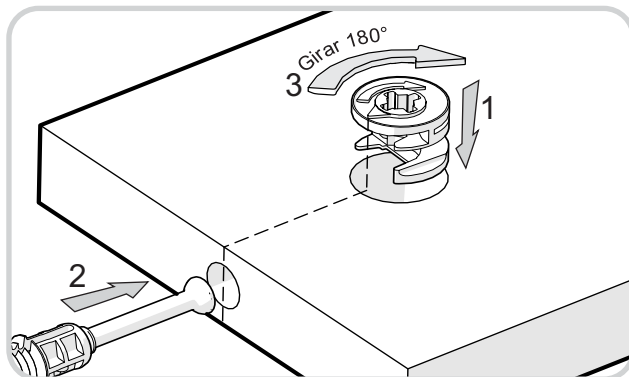

TARUGOS

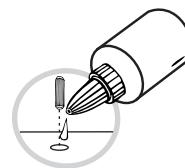
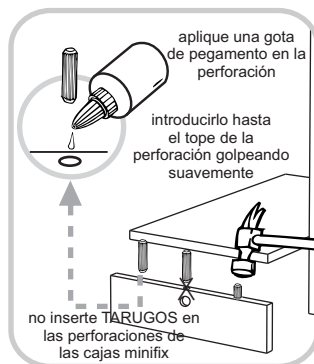

1 Gota x perforación

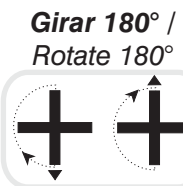
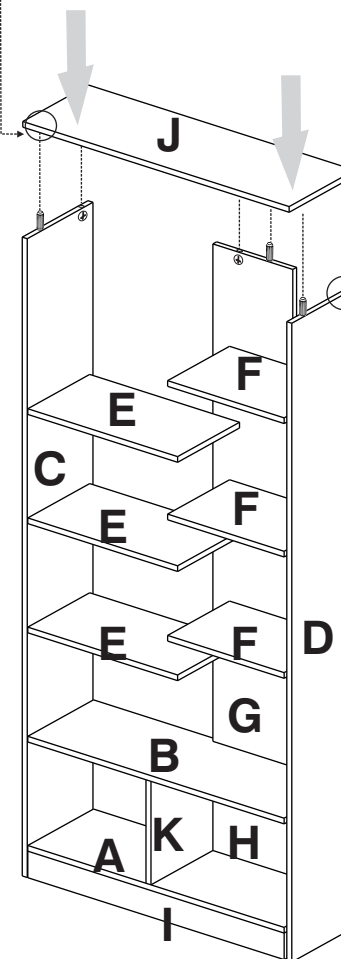

Al terminar de armar desprenda los adhesivos (en caso de que queden residuos de pegamento, limpie la superficie con alcohol) / *When you finish off adhesive build (in case of residues of glue, wipe it with alcohol)*



Al finalizar el ajuste de los conectores, proceda a poner las tapas minifix

Girar 180° /
Rotate 180°

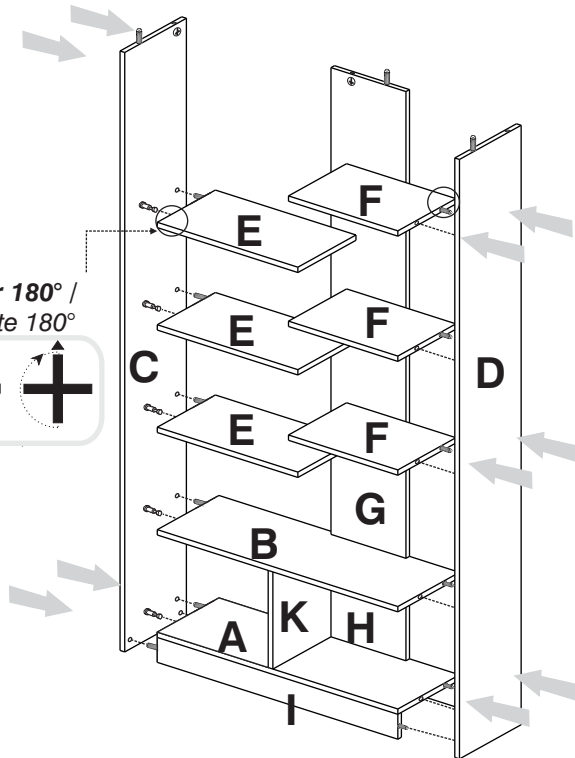
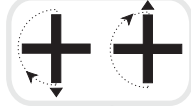

HERRAJES PARA ENSAMBLE

x20



MINIFIX

x20

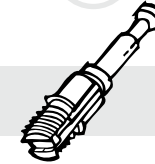

PERNO MINIFIX

x1



PEGANTE

x40



TARUGO

x6



DESLIZADOR

x6



TAPA MINIFIX
CAMELO

x14



TAPA MINIFIX
NEGRA



IMPORTANTE

SE SUGIERE REALIZAR CUADRATURA DE TODAS LAS PARTES Y PIEZAS ANTES DE ARMAR. COMPRUEBE QUE EL CONTENIDO DE LAS PIEZAS SEA EL CORRECTO. EN CASO DE FALTAR ALGUNA O QUE SE ENCUENTRE DEFECTUOSA, SU ARMADOR COORDINARA SU ENVÍO Y REEMPLAZO; TAMBIÉN PUEDE ACERCARSE A ALGÚN PUNTO DE POST VENTA DE LA TIENDA DONDE COMPRO Y SOLICITAR LA PIEZA FALTANTE O DEFECTUOSA

PIEZAS DE ARMADO

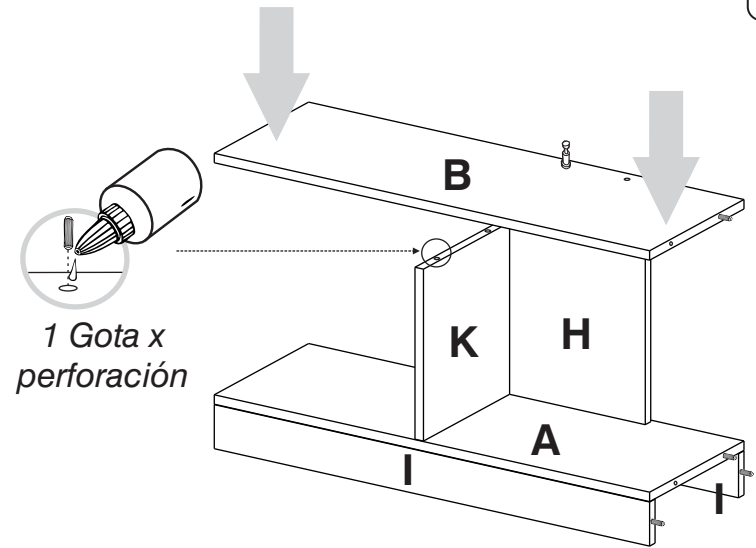
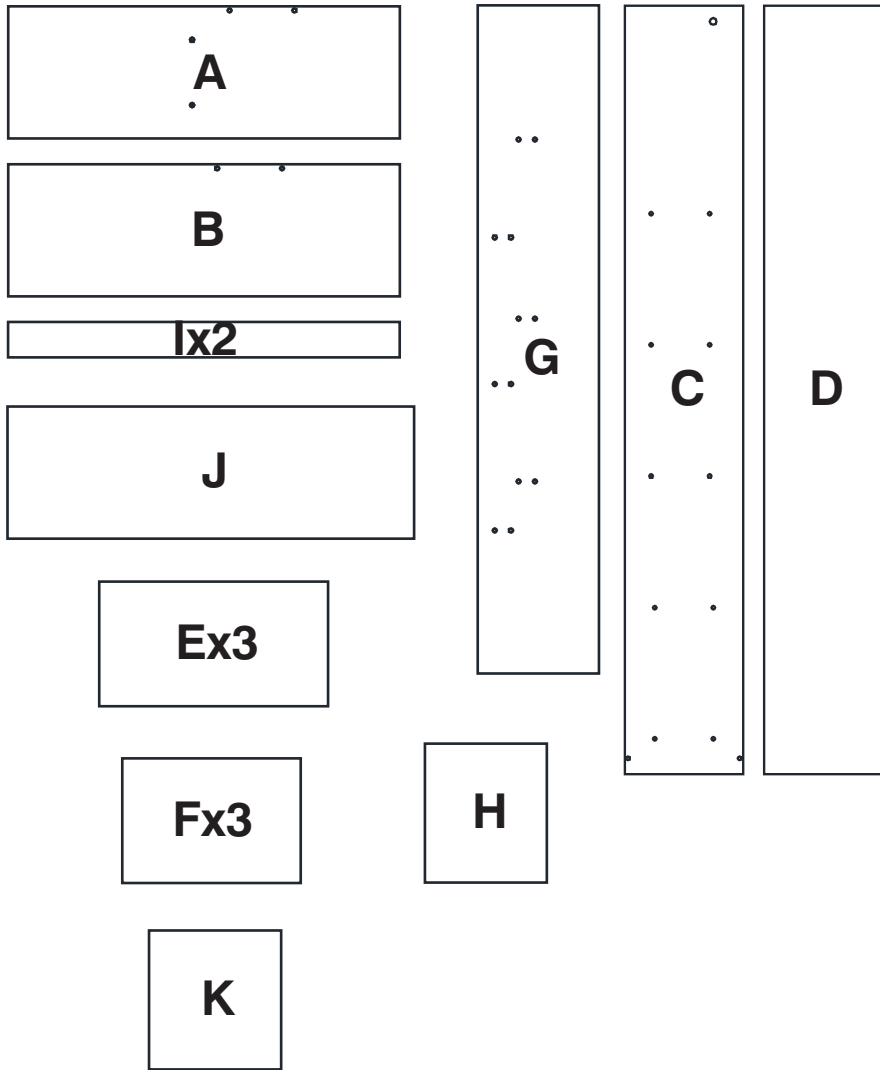

1 Gota x perforación

No olvide apretar todos los conectores

Girar 180° / Rotated 180°



Ensamblar todas las piezas E y F A la Pieza G

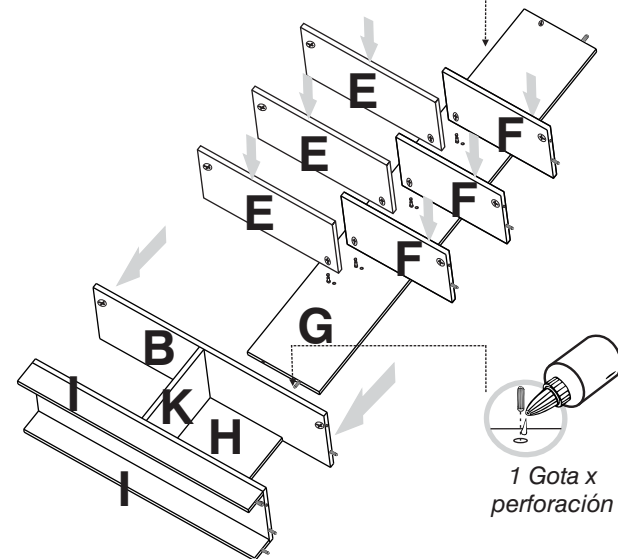

1 Gota x perforación

7

8



IMPORTANTE

ANTES DE EMPEZAR A ARMAR EL MUEBLE LEA DETENIDAMENTE LAS INSTRUCCIONES. SE RECOMIENDA ARMAR EL MUEBLE ACOSTADO SOBRE LA CAJA O SOBRE UNA SUPERFICIE LISA Y CUBIERTA, PARA NO RAYARLO.

5

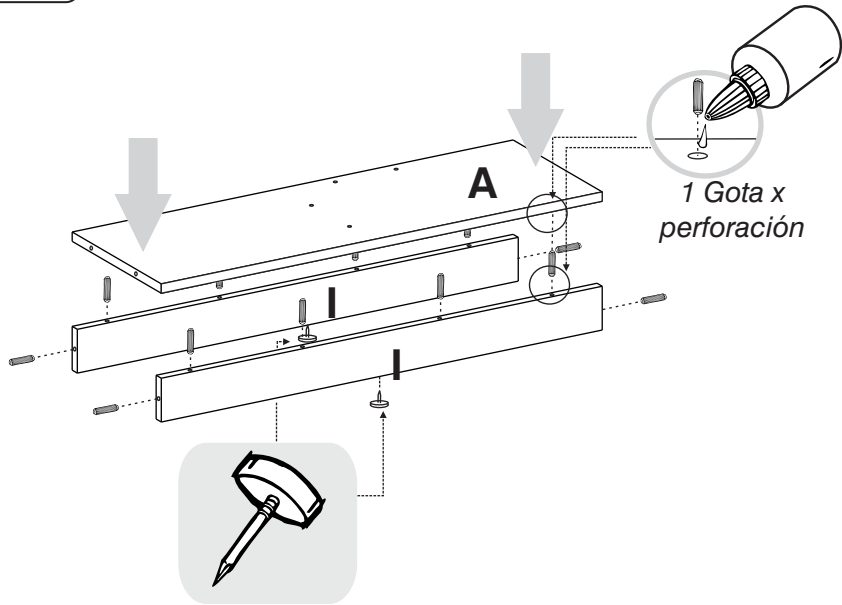

6

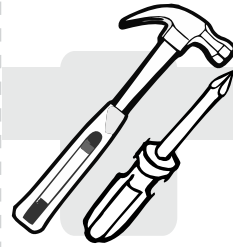
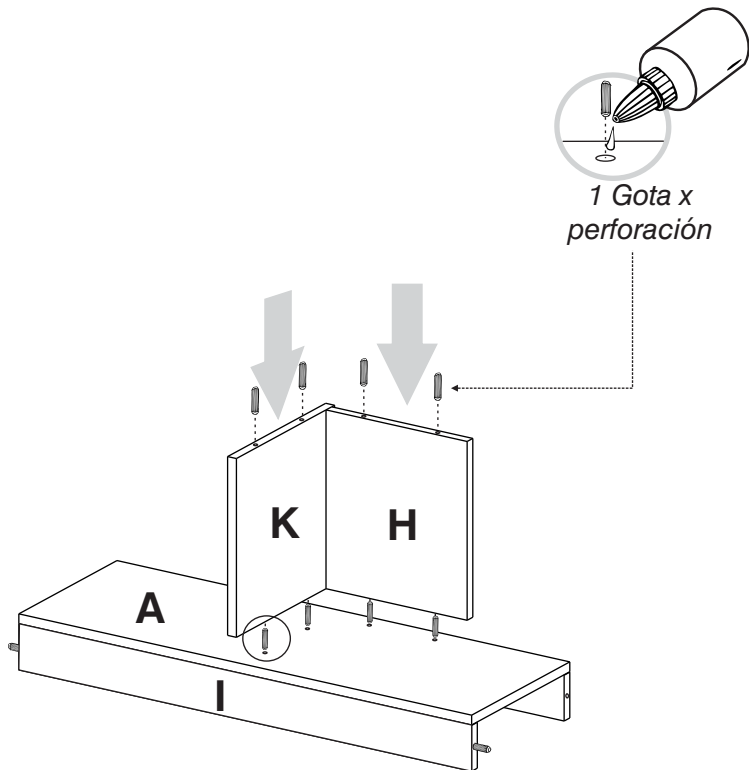

*(Herramientas NO incluidas)

- Martillo
- Destornillador de Estrella

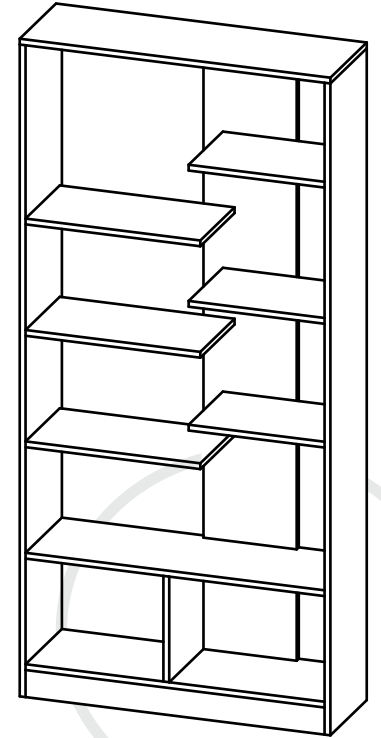
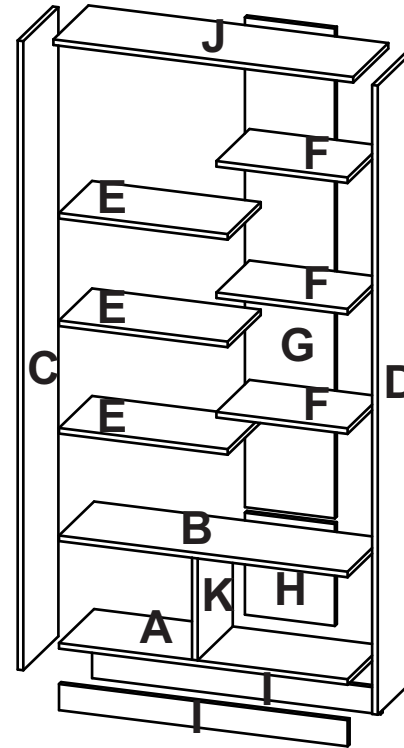

PLANO DE PIEZAS

TUHOME[®]
CONCEPT | DESIGN

1

SE RECOMIENDA ARMAR EL MUEBLE SOBRE LA CAJA O SOBRE UNA SUPERFICIE LISA, PARA NO RAYARLO.

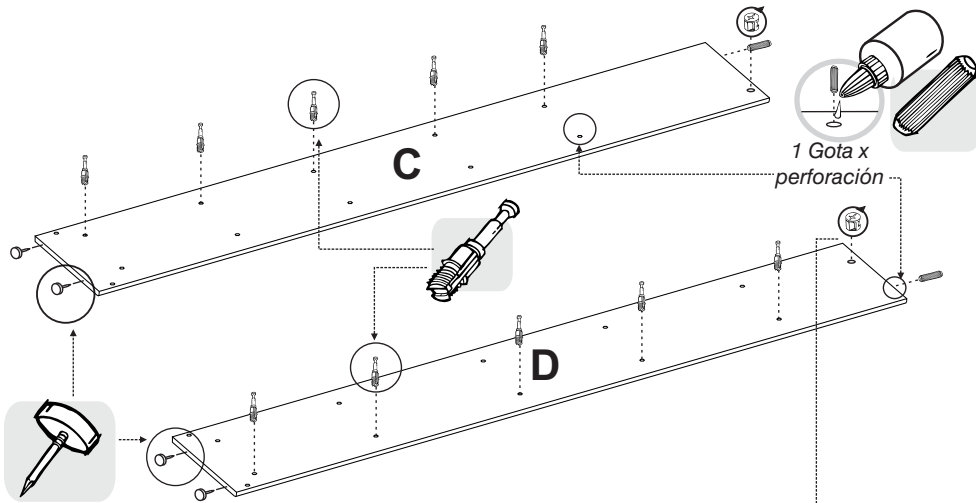
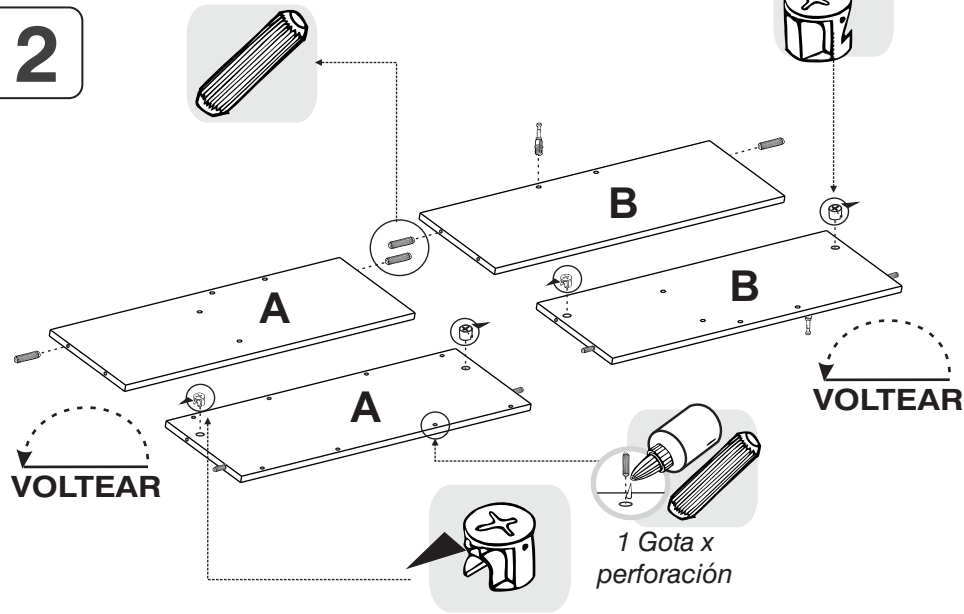
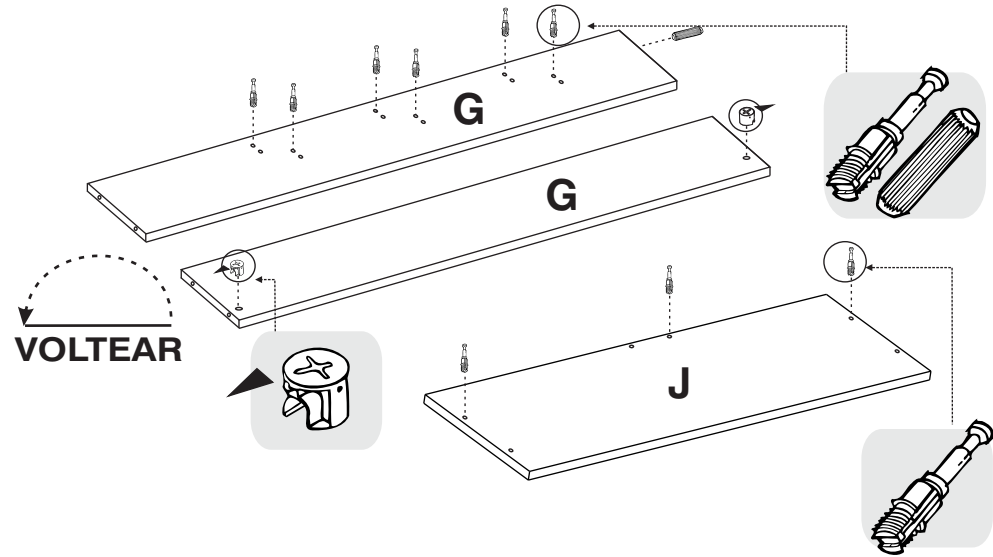
**2****3****4**